

Material:	Hardware: (Pack in plastic bags)
Plywood - 3/4" thk "MDO" (Med. Density Overlay) - Fir Core Resin Paper Veneer Both Sides	(150) #3 FIN. Nails
Horn Sides - 1/4" thk Pine Plywood	(75) #6 FIN. Nails
Cleats, Blocks, etc. - Pine, Fir	(90) #8 x 1-1/4 F.H.W.S.
Braces - Fir	(5) #10 x 1-1/2 R.H.W.S.
Cover - 1/8" thk Masonite	(5) 1/4-20 x 1-1/4 Pic. H. MS. Cad. Plated
Grille Cloth - Lumite 4524704 (Chiroper Mills)	(6) 8-32 x 1-1/4" F.H.M.S.
Glue - 1 pt. Evergrip #55	(4) 8-32 x 1" F.H.M.S.
Decals - (2) 30282	
Fiber Glass - (1) O.C. #701 1-1/2 x 16 x 24	
(2) O.C. #701 1-1/2 x 8 x 16	
(3) O.C. #701 1-1/2 x 21 x 26	

**Marshall's Notes:**

- 1) This part list was redrawn from Altec Lansing's original drawing number 3D438-03.
- 2) Dimensions match the original drawing except for items 14, 15, 16, 17, 23, and 24. Their lengths are adjusted in this drawing to match the assembly drawing. The originals are shorter to ensure easy assembly of the kit. The original lengths are documented in the pdf document if you wish to precisely recreate the kit. However, it is recommended that you start with the dimensions shown in this drawing for these items and make fine adjustments as the cabinet is assembled.
- 3) Special jigs are required to cut the horn flares (6). The intersection of the flare with the sloping bottom plate (7) forms a complex edge that curves. The best way to cut these for small quantities is to leave the bottom of (6) square and pre-assemble the horn components and cut the slope after the glue dries. More details are provided in the pdf file.
- 4) Item (12) matches the dimensions in the original drawing, however these dimensions are for a 3/8" thick flare (6). The kit drawing specifies a 1/4" thick flare. The thinner flare is adequate and easier to form the curved shape than the 3/8" flare. There is a separate drawing that shows the error and the correct size for this part for both a 1/4" flare and a 3/8" flare. A third "horn side" brace (12) is recommended for the 1/4" flare midway between the braces shown in the assembly drawing.
- 5) Item 19a and 19b are listed in the material list (left) as 1/8" thick masonite. On the drawing they are specified to be 1/4" hardboard. Choose the thick material.

**ALTEC**

**828B L.F. HORN KIT**

Original Drawing: 3D438-03

Date: 17 Mar 72

Redrawn by: Marshall Kay  
Raleigh, NC 27606  
mdkay@mindspring.com  
26 Aug 2004

Section B-B

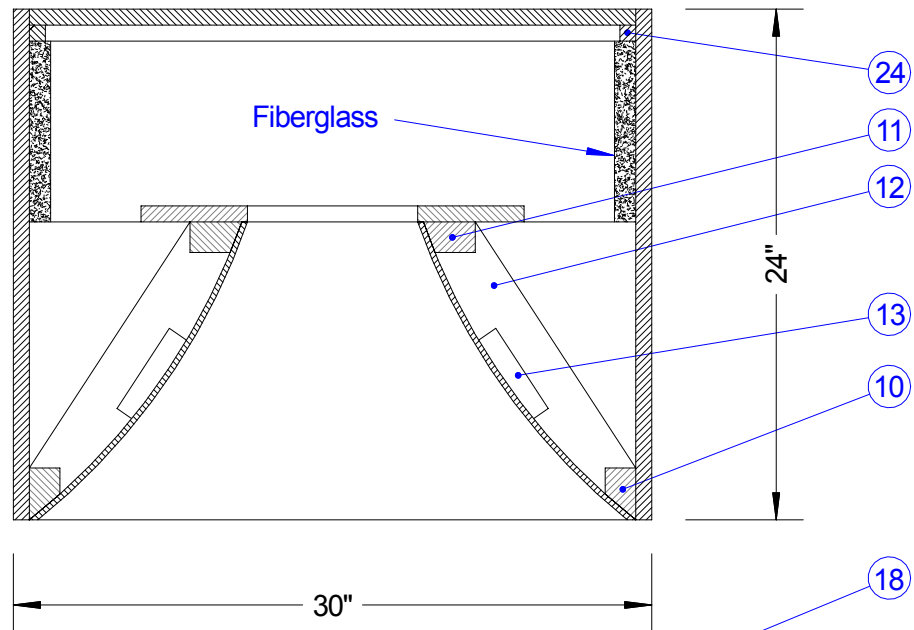

Note: All joints and panels shall be glued and nailed (or screwed) unless removable.

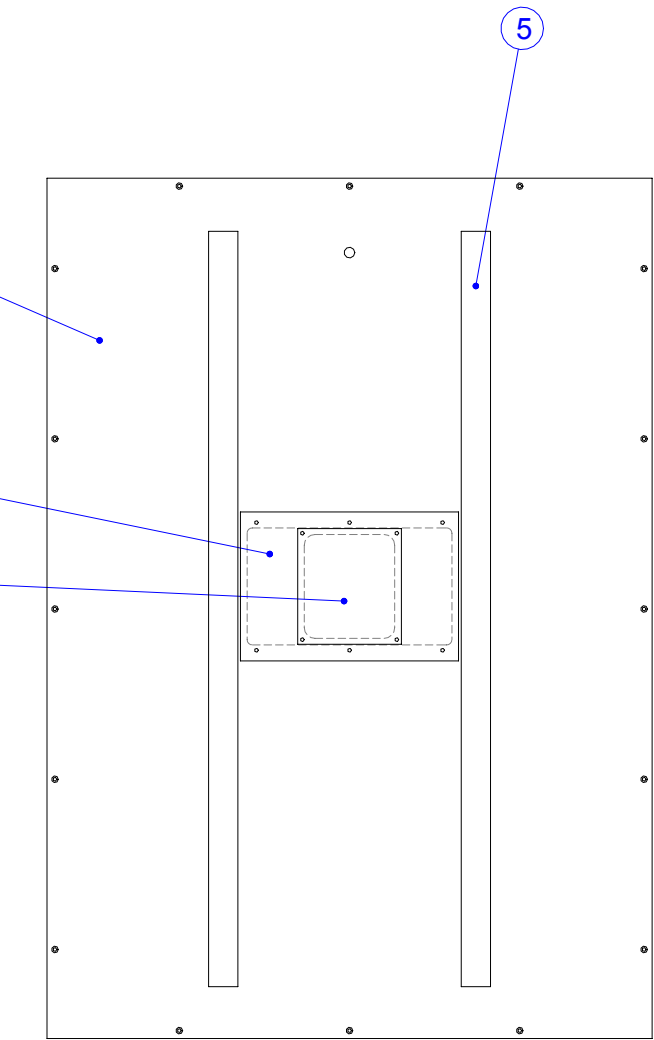
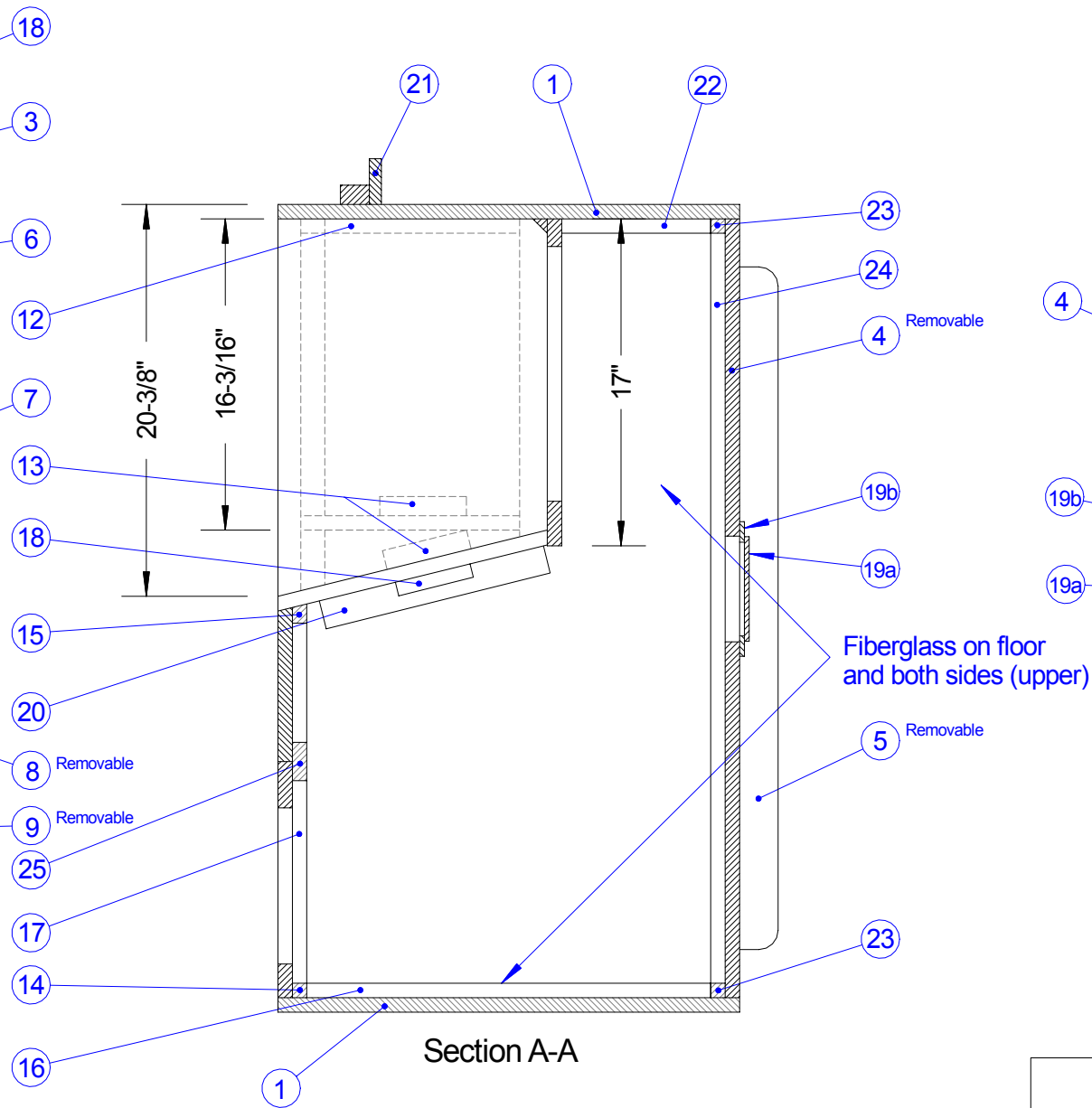
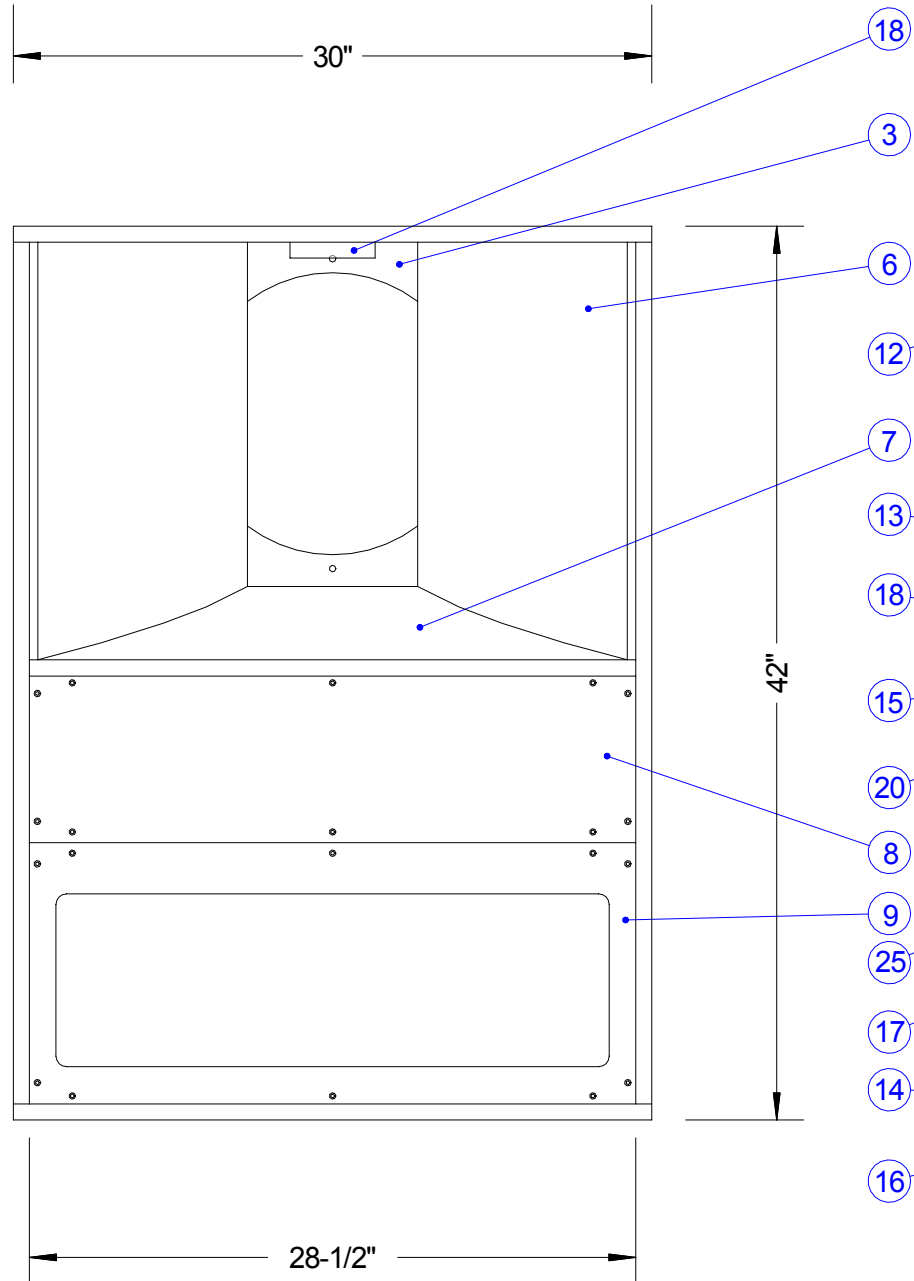

Section A-A

# ALTEC LANSING

Redrawn By:  
 Marshall Kay  
 Raleigh, NC 27606  
 mdkay@mindspring.com

Assembled 828 LF Horn

Date:  
 27 Aug 2004